

# Data Sheet

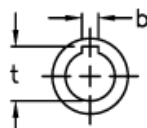

Article number: 2301077721  
Description: E+G Handwheel  
VR.250 FP+I

## Measures

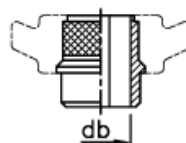
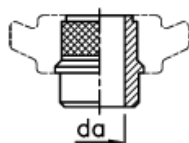
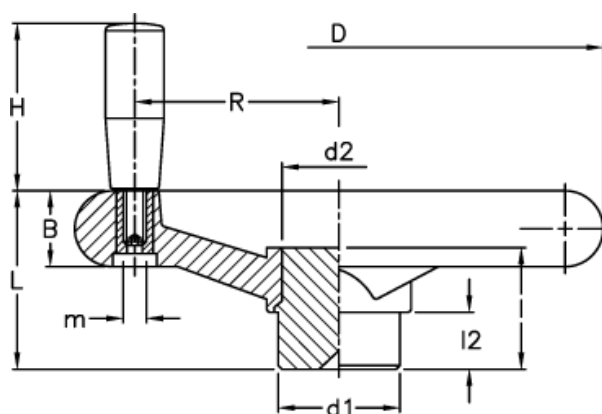

da max tilladelig boring uden not

db max tilladelig boring med not

b	= 8	H	= 90
B	= 30	l	= 44
C (N m)	= 405	L	= 66
D	= 247	L (J)	= 19
d1	= 49	l2	= 15
d2	= 38	m	= M10
da	= 34	R	= 98
db	= 27	t	= 30.3